

Prepared (also subject responsible if other) ETH/RZX Gábor Bettesch +36 1 437 7918		No. 155 17-CNL 113 337 Uen		
Approved ETH/RZXC (Elemér Lelik)	Checked	Date 2009-03-16	Rev G	Reference GASK2

MTP3/MTP3b/M3UA Test Port for TTCN-3 Toolset with TITAN, Function Specification

Contents

1	Introduction	2
1.1	Revision History	2
1.2	How to read this document.....	2
1.3	Scope.....	2
1.4	References.....	3
1.5	Abbreviations	5
1.6	Terminology	6
2	General	7
3	Function Specification for testing with SEA	8
3.1	Overview	8
3.2	Supported specifications	8
3.3	Interfaces	9
3.3.1	Connection with the SUT.....	9
3.3.2	The User Interface: the Abstract Service Primitives.....	9
3.4	The implemented protocols	10
3.4.1	The classical protocol: the Message Transfer Part	10
3.4.2	The M3UA protocol	14
3.5	Additional services	17
3.5.1	Loopback.....	17
3.5.2	Filtering	17
3.6	Capacity and Limitation	17
4	Function specification for testing with real target.....	18
4.1	Map operation	18
4.2	Data transfer	19
4.3	Unmap operation.....	19
4.4	Error situations	20
4.5	Capacity and Limitations	20
5	Function Specification for testing with SEA in STC mode.....	21
5.1	Connection establishment	21
5.2	Data transfer	21
5.3	Disconnection.....	21
6	Function Specification for testing with real target in STC mode	22

Prepared (also subject responsible if other) ETH/RZX Gábor Bettesch +36 1 437 7918		No. 155 17-CNLC 113 337 Uen		
Approved ETH/RZXC (Elemér Lelik)	Checked	Date 2009-03-16	Rev G	Reference GASK2

1 Introduction

1.1 Revision History

Date	Rev	Characteristics	Prepared
2004-02-25	A	Approved	ETHBAAT
2004-09-28	PB1	Chinese version (MPT) added	ETHGBH
2004-09-30	B	Inspected	ETHGBH
2005-01-27	PC1	Testing of real target added	ETHGBH
2005-02-09	PC2	Modifications according to [26]	ETHGBH
2005-10-12	PD1	New service type MTP3b TTC	EJMTCO
2006-01-20	D	Full revision	EJMTCO
2006-01-27	PE1	New ASPs added	EPTEDIM
2006-02-15	PE2	Corrected after review	EPTEDIM
2006-08-10	E	Full revision	ETHJGI
2006-08-15	PF1	STC mode added	ETHGBH
2008-02-08	PG1	MTPiup mode and Dynamic connection feature added	ETHGBH

1.2 How to read this document

This is the Function Specification for the MTP3/MTP3b/M3UA test port. The MTP3/MTP3b/M3UA test port is developed for the TTCN-3 Toolset with TITAN according to the Requirement Specifications [5],[25],[28],[29],[30]. This document should be read together with Product Revision Information [4].

The knowledge of the TITAN TTCN-3 Test Executor [2] and the TTCN-3 language [1] is essential.

The knowledge of the specifications of Signalling System 7 and M3UA created by ITU-T, ANSI, IETF, TTC and MPT ([10]-[20],[24]) is of importance. Knowledge of Ericsson function specifications [21], [22] is useful.

1.3 Scope

The purpose of this document is to specify the functionality of the MTP3/MTP3b/M3UA test port. The test port can inter-work with

- SEA by means of MPH [6], [7], [8] and [9]
- Real target through M3UA server [26] or M3UA Daemon [27].

Prepared (also subject responsible if other) ETH/RZX Gábor Bettesch +36 1 437 7918		No. 155 17-CNL 113 337 Uen		
Approved ETH/RZXC (Elemér Lelik)	Checked	Date 2009-03-16	Rev G	Reference GASK2

This specification is based on the specifications created by ITU-T, ANSI, TTC, MPT and IETF([10]-[20],[24]) and the related Ericsson functional specifications ([21] and [22]).

In several nodes the GCP over SCTP is implemented, meaning the M3UA layer is missing. In order to minimize the impact on existing GCP over M3UA test suites new modes are added to MTP3/M3UA Test Port, which simulate the lack of MTP3/M3UA layer:

MTP3ServiceType='STC' used for testing with SEA. See chapter 5

MTP3ServiceType='TargetSTC' used for testing real target through M3UA Server. See chapter 6.

1.4 References

- [1] ETSI ES 201 873-1 V3.2.1 (2007-02)
Methods for Testing and Specification (MTS); The Testing and Test Control Notation version 3; Part 1: TTCN-3 Core Language
- [2] 1/198 17-CRL 113 200 Uen
User Guide for TITAN TTCN-3 Test Executor
- [3] 1531-CRL 113 200 Uen
Installation Guide for TITAN TTCN-3 Test Executor
- [4] 109 21-CNL 113 337-8 Uen
MTP3/MTP3b/M3UA Test Port for TTCN-3 Toolset with TITAN,
Product Revision Information
- [5] EED/Z/P-03:015 Rev B
PDU CNES – TTCNV3 Requirement Specification
- [6] SEA homepage:
http://tcs.uab.ericsson.se/products/aps/ste/products/sea/sea_index.html
- [7] 1/155 19-CAA 209 1012 Uen, Rev B:
Interwork Description for MPH (Message Protocol Handler)
component
http://tcs.uab.ericsson.se/products/aps/ste/products/sea/docs/iwd_late_st/IWD_MPH.html
- [8] 2/155 19-CAA 209 1012 Uen, Rev D
Interwork Description for MPH (Message Protocol Handler) libraries
http://tcs.uab.ericsson.se/products/aps/ste/products/sea/docs/iwd_late_st/IWD_MPHclient.html
- [9] /Unknown document number/
Interwork Description for SS7 Signalling Terminal protocol in SEA PA1
http://tcs.uab.ericsson.se/products/aps/ste/products/sea/docs/iwd_late_st/IWD_SS7ST.html

Prepared (also subject responsible if other) ETH/RZX Gábor Bettesch +36 1 437 7918		No. 155 17-CNL 113 337 Uen		
Approved ETH/RZXC (Elemér Lelik)	Checked	Date 2009-03-16	Rev G	Reference GASK2

- [10] ITU-T Recommendations Q.700 (03/93)
Specifications of Signalling System No. 7 (SS7)
INTRODUCTION TO CCITT SIGNALLING SYSTEM NO. 7
- [11] ITU-T Recommendations Q.701 (03/93)
Specifications of Signalling System No. 7 (SS7)
FUNCTIONAL DESCRIPTION OF THE MESSAGE TRANSFER
PART (MTP) OF SIGNALLING SYSTEM NO. 7
- [12] ITU-T Recommendations Q.702 (Blue book)
Specifications of Signalling System No. 7 (SS7)
SIGNALLING DATA LINK
- [13] ITU-T Recommendations Q.703 (07/96)
Specifications of Signalling System No. 7 (SS7)
Signalling Link
- [14] ITU-T Recommendations Q.704 (07/96)
Specifications of Signalling System No. 7 (SS7)
Signalling Network functions and messages
- [15] ITU-T Recommendations Q.707 (Blue Book)
Specifications of Signalling System No. 7 (SS7)
TESTING AND MAINTENANCE
- [16] ITU-T Recommendations Q.710 (Blue Book)
Specifications of Signalling System No. 7 (SS7)
Simplified MTP Version for Small Systems
- [17] ITU-T Recommendations Q.2210 (07/96)
Specifications of Signalling System No. 7 (SS7)
Message Transfer Part Level 3 functions and messages using the
services of ITU-T Recommendation Q.2140
- [18] IETF RFC 3332 (2002 September)
Signaling System 7 (SS7) Message Transfer Part 3 (MTP3) – User
Adaptation Layer
- [19] ANSI T.1.111 (2001)
Signalling System Number 7 (SS7) – Message Transfer Part (MTP)
- [20] TTC JT-Q704 (04/2002)
Message Transfer Part (MTP), Signalling Network Functions
- [21] 3/15517-FAY 112 011/2 Uen Rev B
CCITT7 Signalling System No.7, Message Transfer Part
- [22] 2/1056-FCPW 101 086/P-1 Uen Rev B
M3UA Protocol Specification for SS7 over IP, CNCS 4.0
- [23] ITU-T Recommendations Q.2140 (1995)
B-ISDN signalling ATM Adaptation Layer (SSCF and NNI)

Prepared (also subject responsible if other) ETH/RZX Gábor Bettesch +36 1 437 7918		No. 155 17-CNLC 113 337 Uen		
Approved ETH/RZXC (Elemér Lelik)	Checked	Date 2009-03-16	Rev G	Reference GASK2

- [24] GF001-9001 (August 1990)
Technical Specifications of SS7 for National Telephone Network of China
- [25] 15/0363 FCPW 101 97/F Uen Rev C
TTCNV3 Requirement Specification for MSC R12
- [26] 109 21-CNLC 113 410-1 Uen
M3UA Server for TTCN-3 Toolset with TITAN, Product Revision Information
- [27] 109 21-CNLC 113 487-3 Uen
M3UA SCTP Daemon for TTCN-3 Toolset with TITAN, Product Revision Information
- [28] 16/0363 FCPW 101 97/E Uen Rev A
Requirement Specification: MTP3/M3UA, SCCP and TCAP Test Port Improvements
- [29] 5/0363-1/FCP 101 2180-CR3 Uen Rev A
MSC-S BC Changes and Improvements
- [30] 6/0363 FCP 101 3665/P Uen Rev A
TTCNV3 Requirement Specification for MSC R13

1.5 Abbreviations

ANSI	American National Standards Institute
ASP	Abstract Service Primitive
ATM	Asynchronous Transfer Mode
BICC	Bearer Independent Call Control
DPC	Destination Point Code
IETF	Internet Engineering Task Force
IP	Internet Protocol
ISUP	ISDN User Part
ITU	International Telecommunication Union
ITU-T	Telecommunication Standardization Sector of ITU
IUP	Interconnect User Part
IUT	Implementation Under Test
MPH	Message Protocol Handler

Prepared (also subject responsible if other) ETH/RZX Gábor Bettesch +36 1 437 7918		No. 155 17-CNL 113 337 Uen		
Approved ETH/RZXC (Elemér Lelik)	Checked	Date 2009-03-16	Rev G	Reference GASK2

MPT	Ministry of Post and Telecommunications (People's Republic of China)
MSU	Message Signal Unit
MTP3	Message Transfer Part level 3
MTP3b	MTP3 adaptation for Q.2140
M3UA	SS7 MTP3 User Adaptation Layer
NI	Network Indicator
OPC	Originating Point Code
PDU	Protocol Data Unit
RFC	Request For Comments
SEA	Simulator Environment Architecture
SIF	Service Information Field
SIO	Service Information Octet
SPC	Signalling Point Code
SS7	Signalling System No 7
SCTP	Stream Control Transmission Protocol
SUT	System Under Test
TTCN-3	Testing and Test Control Notation version 3
TTC	Telecommunications Technology Committee (Standardization body of Japan)

1.6 Terminology

MTP3	MTP level 3, the signalling network layer of SS7
MTP3-User	Any protocol normally using the services of the SS7 MTP3 or M3UA (e.g. ISUP, SCCP, TUP, etc).
M3UA	MTP3 User Adaptation Layer. M3UA is a protocol supporting the transport of any SS7. MTP3-User signalling over IP using the services of the SCTP protocol. (See [18])
Test Port	An adaptation between the TTCN-3 Test Executor and the SUT.

Prepared (also subject responsible if other) ETH/RZX Gábor Bettesch +36 1 437 7918		No. 155 17-CNL 113 337 Uen		
Approved ETH/RZXC (Elemér Lelik)	Checked	Date 2009-03-16	Rev G	Reference GASK2

- SEA Simulator Environment Architecture, provides the possibility to have simulated AXE nodes running on a Unix workstation.
- STC Mode In this mode the implementation of MTP3 layer or the M3UA layer is missing. It was introduced to be able to test GCP over SCTP with the same test cases as GCP over M3UA, but it can be used also to test the MTP3 layer or the M3UA layer itself.

2 General

This Test Port is developed for testing higher level protocols over the already tested MTP3 and M3UA protocols.

In STC mode it can be used for testing the MTP3 and M3UA protocols themselves.

The test port implements the MTP3 protocol specified by ITU-T in [10]-[17], by ANSI in [19], by TTC in [20], by MPT in [24] and M3UA specified in [18].

The SUT can be

- Simulator Environment Architecture (SEA) and the software implementation loaded in it
- Real target through M3UA Server [26] or M3UA Daemon [27]

The user of the test port ("MTP3-User") is any next higher level protocol.

The test port communicates with its user by means of Abstract Service Primitives (ASPs), described below. The test port communicates with its peer protocol by means of messages i.e. protocol data units (PDUs).

Prepared (also subject responsible if other) ETH/RZX Gábor Bettesch +36 1 437 7918		No. 155 17-CNL 113 337 Uen		
Approved ETH/RZXC (Elemér Lelik)	Checked	Date 2009-03-16	Rev G	Reference GASK2

3 Function Specification for testing with SEA

3.1 Overview

The test port provides the following functionalities:

- Builds a connection to the SUT (see 3.3.1).
- Makes a mapping between ASPs (see 3.3.2) and messages (PDUs) carried by MPH according different specifications (see 3.2)
- Implements some management functionalities

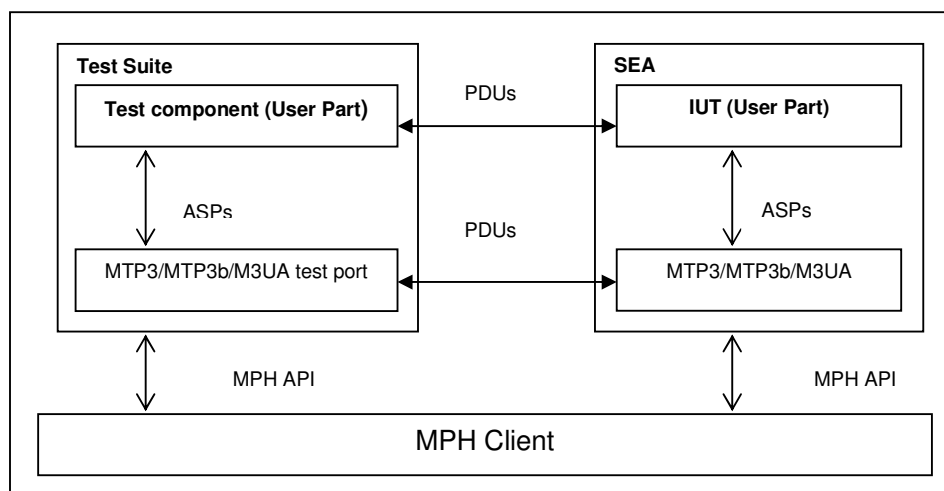

Figure 1 The overview of the test system using MTP3/MTP3b/M3UA test port

3.2 Supported specifications

The service type or the “flavour” of the test port defines which specification should be followed. The service type of the test port and its peer should be identical.

These types are:

- MTP3 ITU-T (applies [10]-[16])
- MTP3 ITU-T for IUP
- MTP3 ANSI (applies [19])
- MTP3 TTC and MTP3b TTC (applies [20])
- MTP3 MPT (applies [24])

Prepared (also subject responsible if other) ETH/RZX Gábor Bettesch +36 1 437 7918		No. 155 17-CNL 113 337 Uen		
Approved ETH/RZXC (Elemér Lelik)	Checked	Date 2009-03-16	Rev G	Reference GASK2

- M3UA IETF (applies [18])

These are discussed in the following chapters (see chapter 3.4).

3.3 Interfaces

3.3.1 Connection with the SUT

The Test Port provides two connection modes –determined via configuration parameter- for connection establishment between the executable test suite and the SEA.

In a semi-static connection mode the connection is built up whenever a `map` operation is requested in TTCN-3 and disconnection is issued when an `unmap` operation is called.

In dynamic connection mode the connection is built up only via calling function `f_MTP3_SEA_connect` and disconnection is issued when `f_MTP3_SEA_disconnect` function is called.

The test port opens an MPH channel (see [7] and [8]) and establishes the connection between the MPH Interface of SEA and the test component. The MPH interface is of the “SS7 Signalling Protocol” type (see [9]).

The communication goes on protocol MTP3, MTP3b or M3UA according the variable settings in the configuration file of the test suite.

3.3.2 The User Interface: the Abstract Service Primitives

These ASPs and their behaviour rules are identical in MTP3 and M3UA. In other words MTP3 and M3UA are identical from the MTP3-User’s point of view.

The ASPs of the test port are a subset of MTP primitives as they specified in [11], [18], [19], [20] and collected in Table 1.

ITU-T, ANSI, IETF and TTC names			Test port
Generic name	Specific name	Parameters	ASP name
MTP-TRANSFER	Request or indication	OPC, DPC, SLS, SIO, User data	ASP_MTP3_TRANSFERreq, ASP_MTP3_TRANSFERind
MTP-PAUSE	Indication	Affected DPC	Not implemented
MTP-RESUME	Indication	Affected DPC	ASP_MTP3_RESUME
MTP-STATUS	Indication	Affected DPC Cause	Not implemented

Table 1 Message Transfer Part Service Primitives and their implementation

Prepared (also subject responsible if other) ETH/RZX Gábor Bettesch +36 1 437 7918		No. 155 17-CNLI 113 337 Uen		
Approved ETH/RZXC (Elemér Lelik)	Checked	Date 2009-03-16	Rev G	Reference GASK2

The MTP3 User can send message ASP_MTP3_TRANSFERreq and can receive message ASP_MTP3_TRANSFERind and ASP_MTP3_RESUME.

3.4 The implemented protocols

3.4.1 The classical protocol: the Message Transfer Part

3.4.1.1 Overview of MTP

This chapter is valid for test port implementation of MTP ITU-T ([11]-[16]), MTP ANSI [19], MTP TTC [20] and MTP MPT [24]. They differ from each other only in the size of certain fields, therefore their description and implementation can be performed together.

SS7 is a general purpose common channel signalling (CCS) system. According to the layered architecture described in Q.700 its 3 lower layers constitute the Message Transfer Part (MTP).

“The overall function of the Message Transfer Part is to serve as a transport system providing reliable transfer of signalling messages between the locations of communicating user functions.”

MTP level 1 (MTP1) or “Signalling data link functions” “defines the physical, electrical and functional characteristics of a signalling data link and the means to access it” (see 2.2.2/Q.700 in [10])

MTP level 2 (MTP2) or “Signalling link functions” defines the functions and procedures for the transfer over one individual signalling data link. It defines and handles the Signalling Unit Formats (see Figure A.1/Q.703 in [13]). From our point of view only the basic Message Signal Unit (MSU) is relevant and implemented to a certain extent.

MTP level 3 (MTP3) or “Signalling network functions and messages” (see Q.704) defines network routing, network managing, network testing and message transferring functions. It uses only SIO and SIF (see below).

F Flag (8bits)	CK check bits (16bits)	SIF=Signalling information field (8n bits, n>=2)	SIO (8bits)	BSN, BIB, FIB etc. (48 bits)	Flag > (8bits)
----------------	------------------------	--	-------------	------------------------------	----------------

Figure 2 The Message Signal Unit Format according ITU-T Q.703, T.1.111.3-2001 and JT-Q704

SIO (service information octet) is discussed in 14.2/ Q.704 in [14]. It defines the type of the message if it is a user part signal (e.g. ISUP or SCCP) or if the message is a management or a testing signal. It also contains the network type information (e.g. national, international).

SIF (service information field) contains the label and in particular the routing label (see Figure 3/Q.704 in [14]).

Prepared (also subject responsible if other) ETH/RZX Gábor Bettesch +36 1 437 7918		No. 155 17-CNL 113 337 Uen		
Approved ETH/RZXC (Elemér Lelik)	Checked	Date 2009-03-16	Rev G	Reference GASK2

The only difference from the test point of view is the length of the SIF.

Specification	Length of the SIF in MSU (octets)	Reference
MTP3 ITU-T, TTC, MPT	2...272	2.3.8/Q.703
MTP3 ANSI	2...272	4.3.4/T1.11.1 2.3.8/T1.111.3

Table 2 The length of the SIF

In the SEA simulation the MTP 1-2 are implemented hidden from the Test Port and only the SIO and SIF fields are defined and transferred..

SIF contains the label. The structure of the label is shown in Figure 3, according to 2.2/Q.704 in [14].

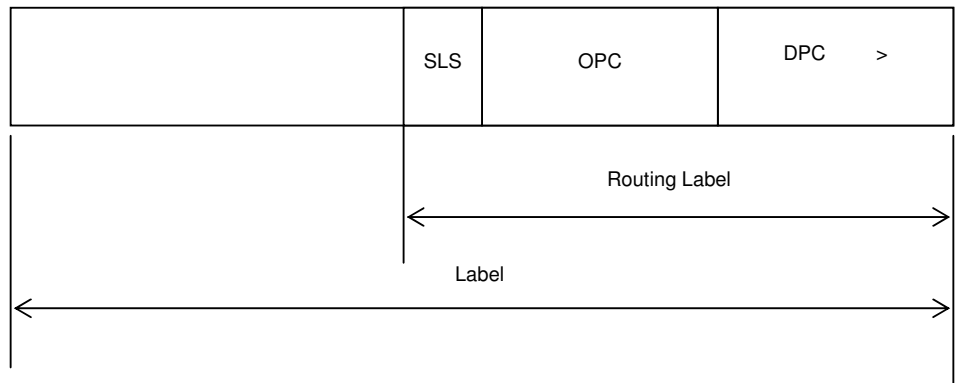

OPC Originating Point Code

DPC Destination Point Code

SLS Signalling Link Selection

Figure 3 Routing label structure (> shows the first bit transmitted)

Specifications ANSI, TTC and MPT are “intended to be compatible with ITU-T Recommendations Q.701 through 710 ” (see [10]-[16]). The main difference from the test point of view is the size of the fields.

The next table summarizes the size of the fields in different national standards. A good comparison is given in the Ericsson function specification [21].

Prepared (also subject responsible if other) ETH/RZX Gábor Bettesch +36 1 437 7918		No. 155 17-CNL 113 337 Uen		
Approved ETH/RZXC (Elemér Lelik)	Checked	Date 2009-03-16	Rev G	Reference GASK2

Field	Length in bits				
	ITU-T	ITU-T for IUP	ANSI	TTC national*	MPT national**
SIO	8	8	8	8	8
DPC	14	14	24	16	24
OPC	14	14	24	16	24
SLS	4	12***	8	4	4

*: If SIO sub-service field >= 2. Otherwise TTC international is the same as ITU-T

** : MPT international is the same as ITU-T

***: This is the CIC field instead of SLS

Table 3 Size of fields in the different national standards

Note: in case of service type MTP3b TTC (ATM TTC National) an additional Priority Octet can be found at the beginning of the message, which is transparently sent back in the next answer message by the test port. In the first message this additional octet is 0.

The message signal units (MSUs) transport information

- a between MTP3-Users
- b between MTP3 levels as inner testing, maintenance and routing information.

Case 'a' is performed by mapping the information between the ASPs and MSUs.

Case 'b' is invisible for the User Part and discussed in following chapters.

3.4.1.2 Supported MTP functions

The test port implements only a subset of the functionality specified by ITU-T, ANSI, TTC and MPT. The reasons of the restrictions are:

- MTP level 1 and level 2 are only simulated as described in section 3.4.
- There is only one signalling link between the test port/suite and the SUT.
- Test port is simplified for testing purposes (e.g. only a subset of the ASPs are implemented)

3.4.1.2.1 Signalling data link functions (level 1)

These functions specified in Q.702 [12], [19] and JT-Q702 cannot be implemented because of a/3.4.1.2. Data transfer is performed, of course.

3.4.1.2.2 Signalling link functions (level 2)

These functions specified in Q.703, [19] and Q.703 and JT-Q701 cannot be implemented because of a/3.4.1.2. Data transfer is performed, of course.

Prepared (also subject responsible if other) ETH/RZX Gábor Bettesch +36 1 437 7918		No. 155 17-CNL 113 337 Uen		
Approved ETH/RZXC (Elemér Lelik)	Checked	Date 2009-03-16	Rev G	Reference GASK2

3.4.1.2.3 Signalling network functions (level 3)

- Signalling network functions can be divided into two basic categories:
- Signalling message handling
- Signalling network management

Here is the list of functions and their implementation status:

Name	Reference	Status of implementation	Reason (cf. 3.4.1.2)	Remark
Signalling message handling/ Message routing	1.2.3/Q.704 2.3/Q.704	Not applicable	b	
Signalling message handling/ Message discrimination	1.2.3/Q.704 2.4/Q.704	Partially	b,c	Implemented as filtering which can be switched off
Signalling message handling/ message distribution	1.2.3/Q.704 2.4/Q.704	Not implemented	c	Only one user can be applied at the same time. Simplified for Distribution=delivery
Signalling network management/ signalling traffic management (changeover, changeback, forced rerouting, controlled rerouting and MTP restart)	1.3.3/Q.704 5-9, 11/Q.704	Partially	b	Answer for request is a must and implemented, see 3.4.1.2.4
Signalling network management/ signalling link management (restoration, activation, inactivation, link set activation, automatic allocations)	1.3.4/Q.704 12/Q.704	Partially	b	Answer for request is a must and implemented, see 3.4.1.2.4
Signalling network management/ signalling route management (transfer-prohibited, transfer-allowed, transfer restricted)	1.3.5/Q.704 13/Q.704	Partially	c	Answer for request is a must and implemented, see 3.4.1.2.4

Table 4 Signalling network functions

3.4.1.2.4 Handling of Network Management Messages by MTP3

The implementation is based on 12/Q.704 and restricted only for giving an answer for any request without any other activities. All messages can be found in Table 1/15.3/Q.704 [14].

In case of management messages the service indicator (SI) field of SIO is 1.

Prepared (also subject responsible if other) ETH/RZX Gábor Bettesch +36 1 437 7918		No. 155 17-CNL 113 337 Uen		
Approved ETH/RZXC (Elemér Lelik)	Checked	Date 2009-03-16	Rev G	Reference GASK2

Implemented answering rules are collected in Table 5. For the listed messages an answer should be sent back. Other messages are logged only. For details see 15.3/Q.704 in [14].

H0/H1	Meaning	Answer
0x51	CBD	CBA (0x61)
0x26 (! Not implemented)	MIM/LUN	MIM/LUA (0x46)
0x16	MIM/LIN	MIM/LID (0x56)

CBD: Change-back declaration signal
CBA: Change-back acknowledgement signal
MIM: Management inhibit messages
LIN: Link inhibit signal
LID: Link inhibit denied signal
LUN: Link uninhibit signal
LUA: Link uninhibit acknowledgement signal

Table 5 Handling of management messages

3.4.1.2.5 Handling of Test and Maintenance Messages by MTP3

All signalling node may periodically send SLTM messages to check if its neighbours are alive. It expects an answer SLTA for it. Therefore the test port sends SLTA for SLTM. In case of SLTA message reception a TRA message is replied. Other messages are logged only. For details see 5/Q.707 in [15]

H0/H1	Meaning	Answer
0x11	SLTM	SLTA (0x21)
0x21	SLTA	TRA (0x17)
0x84	SRA (only in TTC)	Log only

SLTM: Signalling Link Test Message
SLTA: Signalling Link Test Acknowledge message
SRA: Signalling Routing Test Acknowledge message

Table 6 Handling test and maintenance messages by the test port

3.4.2 The M3UA protocol

3.4.2.1 Signal unit formats in M3UA

The M3UA protocol is specified by IETF in its M3UA RFC 3332 [18]. “This protocol is specified for supporting the transport of any SS7 MTP3-User signalling (e.g. ISUP, BICC and SCCP messages) over IP using the services of the SCTP. Also, provision is made for protocol elements that enable a seamless operation of the MTP3-User peers in the SS7 and IP domains”-summarizes the Ericsson document [22].

“M3UA messages consist of a Common Header followed by zero or more variable length parameters, as defined by the message type. All the parameters contained in a message are defined in a Tag Length-Value format as shown below” (see RFC 3332 [18]):

Prepared (also subject responsible if other) ETH/RZX Gábor Bettesch +36 1 437 7918		No. 155 17-CNL 113 337 Uen		
Approved ETH/RZXC (Elemér Lelik)	Checked	Date 2009-03-16	Rev G	Reference GASK2

Octet0 0	7	Octet1 0	7	Octet2 0	7	Octet3 0	7
Version		Reserved		Message Class		Message Type	
Message length							
...							
Message parameters							
...							

Figure 4 The M3UA message

The version is always 1.

The message parameter has the general form described in Figure 5.

Octet0 0	7	Octet1 0	7	Octet2 0	7	Octet3 0	7
Parameter tag				Parameter Length			
Parameter value							

Figure 5 Message parameters in the M3UA message

The received messages can be transferred to the user if the message class is “Transfer message” (=1) and the message type is “Payload data (DATA)” (=1). The DATA message contains the M3UA “Protocol data” (parameter) which is defined as follows:

Octet0 0	7	Octet1 0	7	Octet2 0	7	Octet3 0	7
Protocol data				Length			
Originating Point Code (OPC)							
Destination Point Code (DPC)							
SI		NI		MP		SLS	
M3UA-User Protocol Data (Payload)							

Figure 6 The Protocol data parameter

The MTP3/MTP3b/M3UA user can send messages in the same manner. From the MTP3-User point of view all MTP-TRANSFER primitives can be transmitted.

General description can be found in [18] and in [22].

Prepared (also subject responsible if other) ETH/RZX Gábor Bettesch +36 1 437 7918		No. 155 17-CNL 113 337 Uen		
Approved ETH/RZXC (Elemér Lelik)	Checked	Date 2009-03-16	Rev G	Reference GASK2

M3UA can handle all kinds of messages (Management, transfer, traffic maintenance etc) but only the mentioned Transfer message should be transformed up/down as an MTP-TRANSFER primitive to/from the MTP3-User. Of course, if all MTP primitives were implemented, more messages should be transformed to/from the next upper level. Messages different from Transfer message are received and answered only by the real M3UA layer, or in our case by the test port.

3.4.2.2 M3UA messages

The M3UA messages are listed in the following table. User Part doesn't see most of them. They remain on level 3. (MTP3/) M3UA test port processes them according to the next table:

Message Class	Message Name	Abbrev.	sent	received	answer
Management (MGMT)	Error	ERR	yes	yes	Log
	Notify	NTFY	not applicable 1)		Log
Transfer	Payload Data	DATA	yes	yes	Transform and transfer to/from level4
SS7 Signalling Network Management (SSNM)	Destination Unavailable	DUNA	yes	yes	Log
	Destination Available	DAVA	yes	yes	Log
	Destination State Audit	DAUD	yes	yes	DUNA/DAVA
	Signalling Congestion	SCON	yes	yes	Log
	Destination User Part Unavailable	DUPU	yes	yes	Log
	Destination Restricted	DRST	not applicable 1)		Log
ASP State Management (ASPSM)	ASP Up	ASPUP	yes	yes	ASPUPAck
	ASP Down	ASPDN	yes	yes	ASPDNAck
	Heartbeat	BEAT	no	yes	BEAT_Ack
	ASP Up Ack	ASPUP_Ack	yes	yes	ASPAC
	ASP Down Ack	ASPDN_Ack	yes	yes	Log, status ch
	Heartbeat Ack	BEAT_Ack	yes	no	Log
ASP Traffic Maintenance (ASPTM)	ASP Active	ASPAC	yes	yes	ASPAC_Ack
	ASP Inactive	ASPIA	yes	yes	ASPIA_Ack
	ASP Active Ack	ASPAC_Ack	yes	yes	Log,status ch
	ASP Inactive Ack	ASPIA_Ack	yes	yes	Log
Routing Key Management (RKM)	Registration Request	REG_REQ	not applicable 2)		Log
	Registration Response	REG_RSP	not applicable 2)		Log
	Deregistration Request	DEREG_REQ	not applicable 2)		Log
	Deregistration Response	DEREG_RSP	not applicable 2)		Log

Table 7 M3UA messages

Prepared (also subject responsible if other) ETH/RZX Gábor Bettesch +36 1 437 7918		No. 155 17-CNL 113 337 Uen		
Approved ETH/RZXC (Elemér Lelik)	Checked	Date 2009-03-16	Rev G	Reference GASK2

3.5 Additional services

3.5.1 Loopback

The test port is able to work in *loopback* mode. In that case each signal unit to be sent out will be immediately sent back to the handler of received signals instead of the “real” peer in the SEA. The OPC and DPC aren’t changed. A good test suite can achieve a conversation between two test-driven parts if the loopback is switched on.

This functionality can be switched on/off by setting a parameter in the configuration file.

3.5.2 Filtering

The user (the tester) can select what kinds of signals are received. Signal is received if and only if the OPC, DPC are identical with the values, which are set in the configuration file.

3.6 Capacity and Limitation

In this mode the test port cooperates only with SEA. It is not applicable for testing real SS7 Signalling points.

Sequence control is not supported, because only SIO and SIF are implemented.

Error detection is not supported because only SIO and SIF are implemented.

Other limitations are discussed in previous chapters.

Prepared (also subject responsible if other) ETH/RZX Gábor Bettesch +36 1 437 7918		No. 155 17-CNL 113 337 Uen		
Approved ETH/RZXC (Elemér Lelik)	Checked	Date 2009-03-16	Rev G	Reference GASK2

4 Function specification for testing with real target

If the configuration parameter shows, that the test port is working in target mode, then the test port establishes a connection towards a TCP server. This TCP server should be connected to M3UA Server, which ensures the connection towards the target SUT. In this case the test port just forwards the information (configuration parameters, ASPs) to the remote functionality over the TCP connection. In case of testing target MSC the M3UA functionalities over the TCP are implemented in M3UA Server [26] or in M3UA Daemon [27].

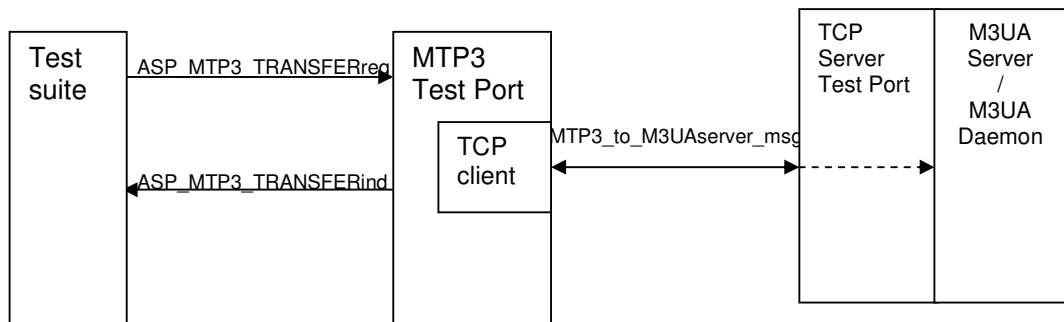

Figure 7 Overview of the possible test system in case of testing target MSC

Byte number	1.	2	3	4	5	6	7	8	9	10	11	12	13	14	15.	16.-n.
TRANSFERind	0	length		sio		opc		dpc			sls		Data			
TRANSFERreq	1	length		sio		opc		dpc			sls		Data			
REGISTER	2	length		ni		sut_pc		tester_pc			m3ua_		system port name			
UNREGISTER	3	length		0												
STATUS	4	length		st.												
PAUSE	5	length		0												
RESUME	6	length		0												

s
st.:
0 REGISTER successful
1 REGISTER unsuccessful
2 UNREGISTER successful
3 UNREGISTER unsuccessful
4 spare
5 M3UA server down
6-255 spare

Table 8 List of messages sent in MTP3_to_M3UAserver_msg

4.1 Map operation

By calling map operation, the test port creates a TCP client and connects to the TCP server (whose location is determined via test port parameters) via using Abstract Socket.

Prepared (also subject responsible if other) ETH/RZX Gábor Bettesch +36 1 437 7918		No. 155 17-CNL 113 337 Uen		
Approved ETH/RZXC (Elemér Lelik)	Checked	Date 2009-03-16	Rev G	Reference GASK2

Over the established TCP connection the parameters of the SUT are sent in REGISTER message. If the connection towards the SUT is established a STATUS message with 'REGISTER successful' value is received and the map operation finishes. If the STATUS received with another value or not received, then the mapping is unsuccessful and the test port stops with an error message.

4.2 Data transfer

The ASPs are collected in Table 9. They are similar to the ones described in chapter 3.3.2. However the test port can receive ASP_MTP3_PAUSE, ASP_MTP3_RESUME and ASP_MTP3_STATUS too.

If an ASP_MTP3_TRANSFERreq received from the test suite, then it is packed into the MTP3_to_M3UAserver_msg – TRANSFERreq message and sent over the TCP connection.

If an MTP3_to_M3UAserver_msg – TRANSFERind message is received over the TCP connection then this message is mapped into an ASP_MTP3_TRANSFERind and sent to the test suite.

ASP_MTP3_PAUSE is received when the M3UA instance is not active in the M3UA server. ASP_MTP3_RESUME indicates that the M3UA instance has become active again. ASP_MTP3_STATUS is received on unsuccessful sending of M3UA messages.

ITU-T, ANSI, IETF and TTC names			Test port
Generic name	Specific name	Parameters	ASP name
MTP-TRANSFER	Request or indication	OPC, DPC, SLS, SIO, User data	ASP_MTP3_TRANSFERreq, ASP_MTP3_TRANSFERind
MTP-PAUSE	Indication		ASP_MTP3_PAUSE
MTP-RESUME	Indication		ASP_MTP3_RESUME
MTP-STATUS	Indication		ASP_MTP3_STATUS

Table 9 MTP Service Primitives and their implementation for testing with real target

4.3 Unmap operation

By calling unmap operation, the test port sends UNREGISTER message over the TCP connection and waits until "UNREGISTER successful" is received in STATUS message. The received TRANSFERind messages are ignored. (If something else or nothing is received, then the test port stops with error.) After reception of "UNREGISTER successful" the test port closes the TCP connection through the Abstract Socket.

Prepared (also subject responsible if other) ETH/RZX Gábor Bettesch +36 1 437 7918		No. 155 17-CNL 113 337 Uen		
Approved ETH/RZXC (Elemér Lelik)	Checked	Date 2009-03-16	Rev G	Reference GASK2

4.4 Error situations

The MTP3 Test Port can receive ASP_MTP3_PAUSE, ASP_MTP3_RESUME and ASP_MTP3_STATUS from the M3UA server to handle the case when the M3UA instance is not active in the M3UA server. For more information see section 4.2.

4.5 Capacity and Limitations

None.

Prepared (also subject responsible if other) ETH/RZX Gábor Bettesch +36 1 437 7918		No. 155 17-CNL 113 337 Uen		
Approved ETH/RZXC (Elemér Lelik)	Checked	Date 2009-03-16	Rev G	Reference GASK2

5 Function Specification for testing with SEA in STC mode

5.1 Connection establishment

By map operation an MPH connection is established towards the SEA entity determined via the Test Port Parameters. See [6],[7],[8],[9].

5.2 Data transfer

The same ASPs are used as in other modes, but only the 'data' field is used. Every other field is filled with 0.

When ASP_MTP3_TRANSFERreq is received from TTCN, then the 'data' field is forwarded to the SEA without any modification.

At reception of any message from SEA the message is put into the 'data' field of ASP_MTP3_TRANSFERind and every other field is filled with 0.

5.3 Disconnection

At unmap operation the MPH connection towards SEA is closed.

Prepared (also subject responsible if other) ETH/RZX Gábor Bettesch +36 1 437 7918		No. 155 17-CNL 113 337 Uen		
Approved ETH/RZXC (Elemér Lelik)	Checked	Date 2009-03-16	Rev G	Reference GASK2

6 Function Specification for testing with real target in STC mode

The function specification described in chapter 4 is valid for this case with the following modifications:

- sio, opc, dpc, sls, ni, sut_pc, tester_pc fields are unused and are always 0.
- m3ua_ver field is 0, which shows to the M3UA Server / M3UA Daemon that the received registration belongs to a user in STC mode.